

· GH ·

CRANES & COMPONENTS

OPEN WINCH

For process cranes and high capacities



**STANDARD
OPEN WINCH
LARGE RANGE
FROM 6.3T TO 400T**



These type of crabs are produced on demand to address special needs such process cranes with special features of capacity, safety, speed or other requirements.

It is called Open Winch due to all the elements are manufactured with independent and different sub-assemblies for easy maintenance.



WHY AN OPEN WINCH?

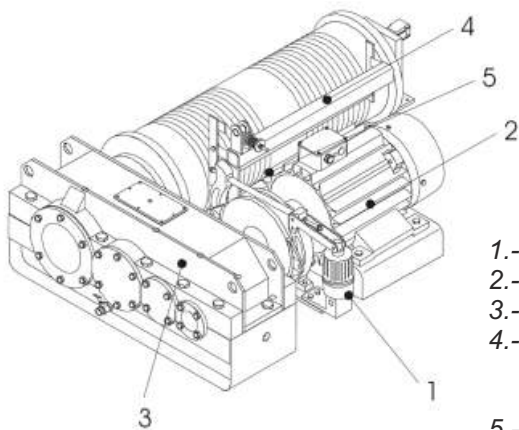

OPEN WINCH ADVANTAGES:

- In general, open winches allow higher lifting capacities, higher speeds and higher FEM working groups.
- Possibility of working with motors of 1,500 rpm., 1,000 rpm. , and 750 rpm. , Bigger motor sizing.
- Commercial motors usage to adequate customer standards. One motor instead with less failure possibility instead of two hoist with two motors for the same lifting capacity.
- Direct shaft from motor to gearbox to drum with flexible and intermediate assemblies, absorbing the shocks at the time of lifting.
- True vertical lift, with stable hook at the lifting time.
- Easy access to the components for easy maintenance.
- External brake for easy access and maintenance
- Wire rope press roller/ Wire rope anti-overlapping and
The anti-overlapping device target is to avoid the wire rope come out from the drum hole.

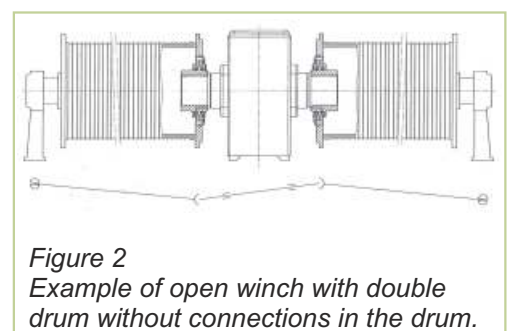
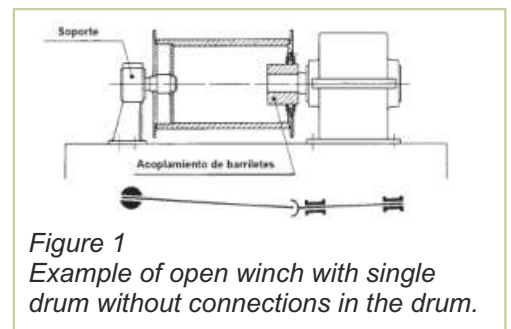

The inaccuracies in assembly, as well as the deformation of the structures and wear of parts in operation, cause huge additional forces, especially in the gearbox output shaft. These forces will cause bending forces that finally may cause fatigue fractures and damages of bearings and gears.

The barrel coupling installed between the gearbox and the drum makes the union statically determined, and therefore avoids the occurrence of high bending moments.

HOISTING

1E - GHA,GHB11, GHD13 hoists

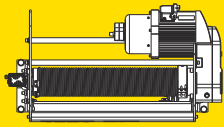

2E - GHE, GHF, GHG Hoists

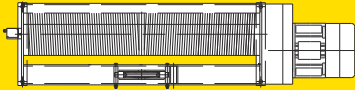

3E - Single open winch

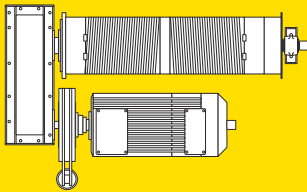

4E - Double open winch with double drum

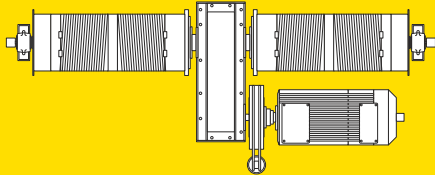

5E - Double rotating open winch with double drum

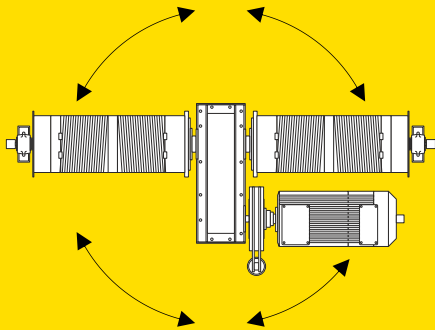

6E - Open winch with double planetary gearbox double drum and safety brake drum

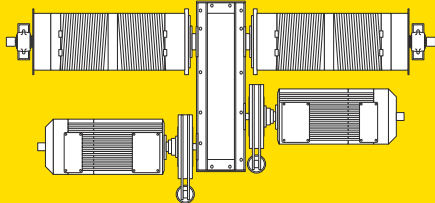

7E - Redundant security, double planetary reduction drum brake drum safety

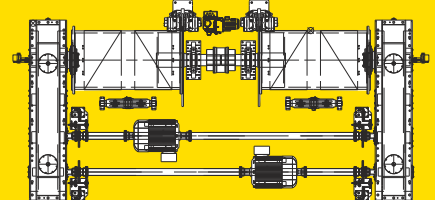

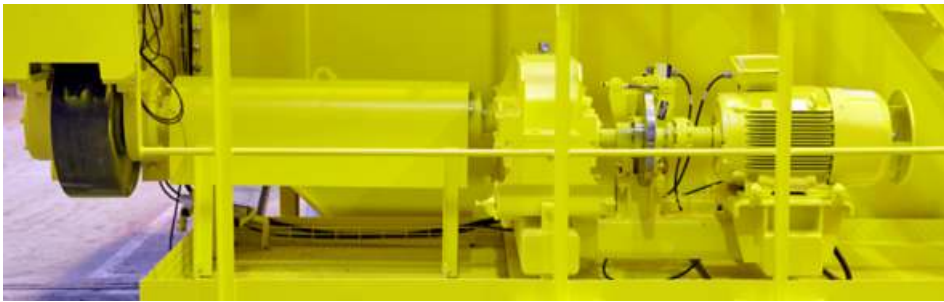

1T - Open winch

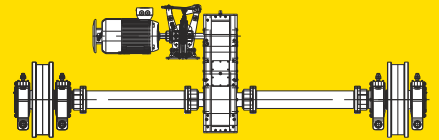

2T - Open winch and cranes

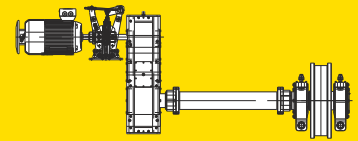

3T - Open winch and cranes

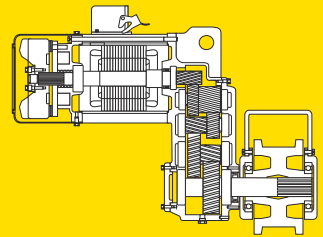

4T - Horizontal roller

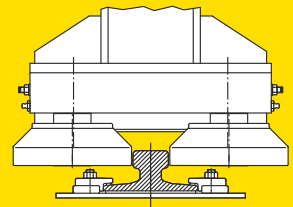

5T - Turn

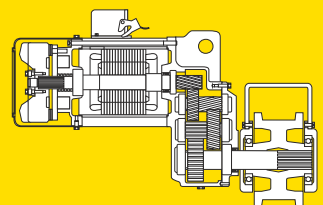

FEM CLASSIFICATION

According to the FEM classification, two criteria select the working duty:

- Load spectrum (K)
- Daily Usage average time (Tm)

SERVICE CLASS

Approximate method

LIGHT-L1

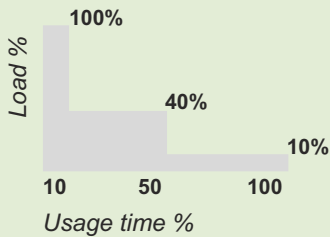

Occasionally full load usage
Normally low load usage

MEDIUM - L2

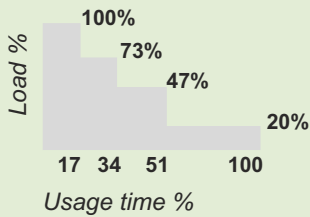

Occasionally full load usage
Normally medium load usage

HIGH - L3

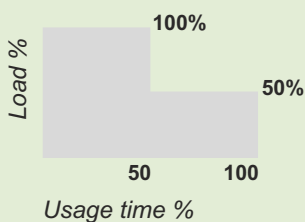

Usually at full load
Usually at medium load

VERY HIGH - L4

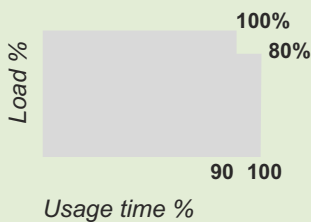

Almost always at full load usage

Load spectrum	k	Tm			
L1 Light	$k < 0,5$	4-8	8-16	>16	
L2 Medium	$0,5 < k < 0,63$	2-4	4-8	8-16	>16
L3 High	$0,63 < k < 0,8$	1-2	2-4	4-8	8-16
L4 Very high	$0,8 < k < 1$	0,5-1	1-2	2-4	4-8
	FEM	2m	3m	4m	5m
	ISO	M5	M6	M7	M8
	CMAA	C	D	E	F
	GOST	3M	4M	5M	6M

High load capacity	10 t	C
Medium high elevation	6 m	Lh
Hoisting speed	5 m/min	V
Cycle No./Hours	12	Ch
Working hours/day	8 hours	Hd
State solicitation	Medium	

$$T_m = \frac{2 \times L_h \times C_h \times H_d}{60 \times V}$$

$$T_m = \frac{2 \times 6 \times 12 \times 8}{60 \times 5} = 2,56 \text{ [hours]}$$

For a medium load spectrum the is a time fo2.56 hours per day and the board shows a **M5** group.

Load spectrum (k) can be determined exactly as follows

$$k = \sqrt[3]{\left(\frac{C_1}{C}\right)^3 \cdot \left(\frac{T_i}{T_m}\right) \dots \left(\frac{C_n}{C}\right)^3 \cdot \left(\frac{T_i}{T_m}\right)}$$

Where (Each cycle)

Ci Partial load

Ti Special cargo usage time

SELECTION TIME

■ Mechanism selection group according to the capacity board

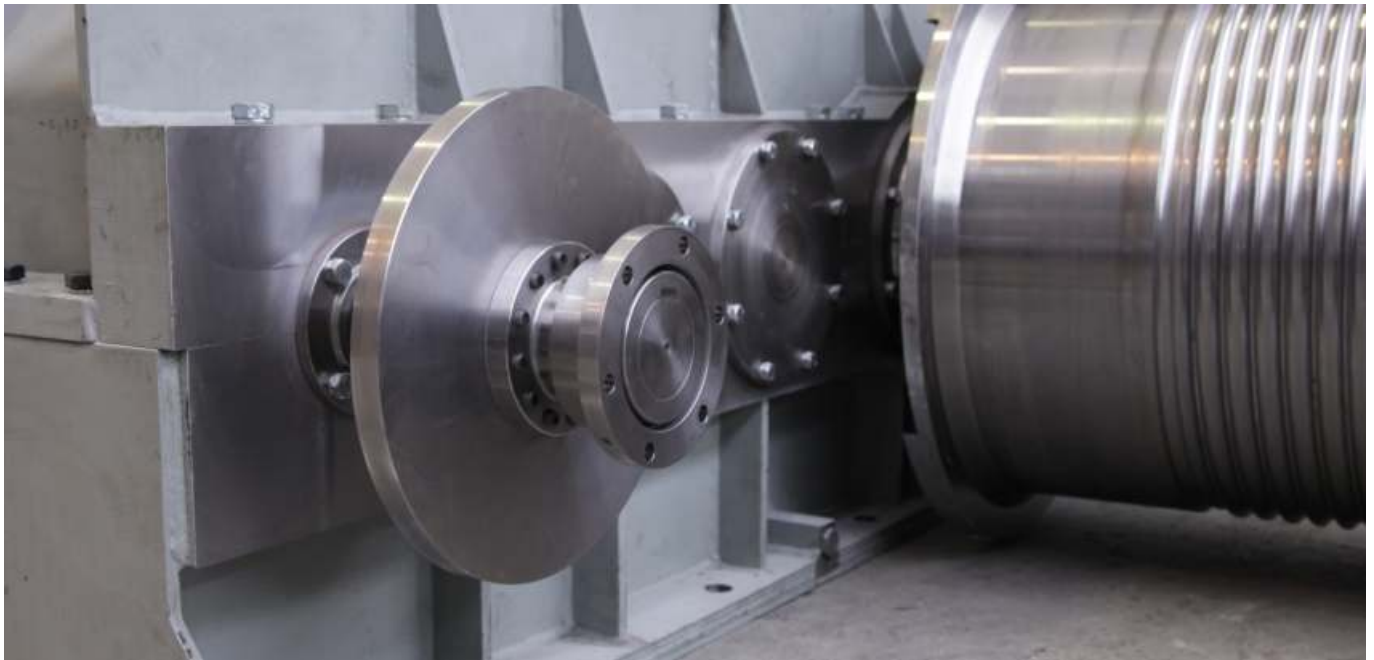

Falls	GHF			GHG			GHI			GHJ				GHK			
Load (TN)	4/2	8/2	12/2	4/2	8/2	12/2	4/2	8/2	12/2	4/2	8/2	12/2	16/2	4/2	8/2	12/2	16/2
6,3	M8																
8	M8																
10	M8																
12,5	M7	M8		M8													
16	M6	M8		M8													
20	M5	M8		M7			M8										
25		M7	M8	M6	M8		M8										
32		M6	M8	M5	M8		M7			M8							
40		M5	M7	M4	M7	M8	M6	M8		M8							
50			M6		M6	M8	M5	M8		M7				M8			
63			M5		M5	M7		M7	M8	M6	M8			M7			
80					M4	M6		M6	M8	M5	M8			M6			
100						M5		M5	M7		M7	M8		M5	M8		
125									M6		M6	M8		M4	M7		
160									M5		M5	M7	M8		M6	M8	
200												M6	M7		M5	M7	M8
250												M5	M6		M4	M6	M7
320													M5			M5	M6
400																M4	M5

Coding proposal:

025M8I042B3R08
25 tn capacity
FEM M8 group

Gearbox type
42 4/2 wire rope falls
B motor flange (motor flange=B motor fix=P)

3R stage gearboxes
8 m/min speed

SELECTION TIME

■ Selection board for open winch selection with 4/2 falls

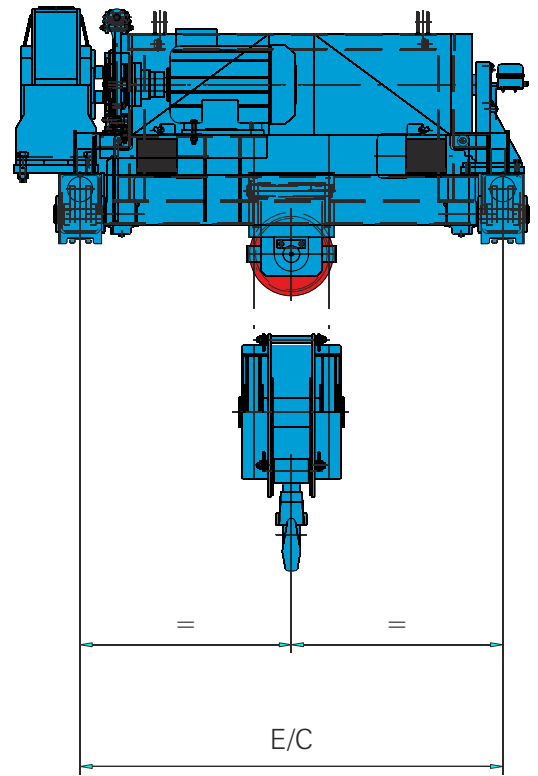
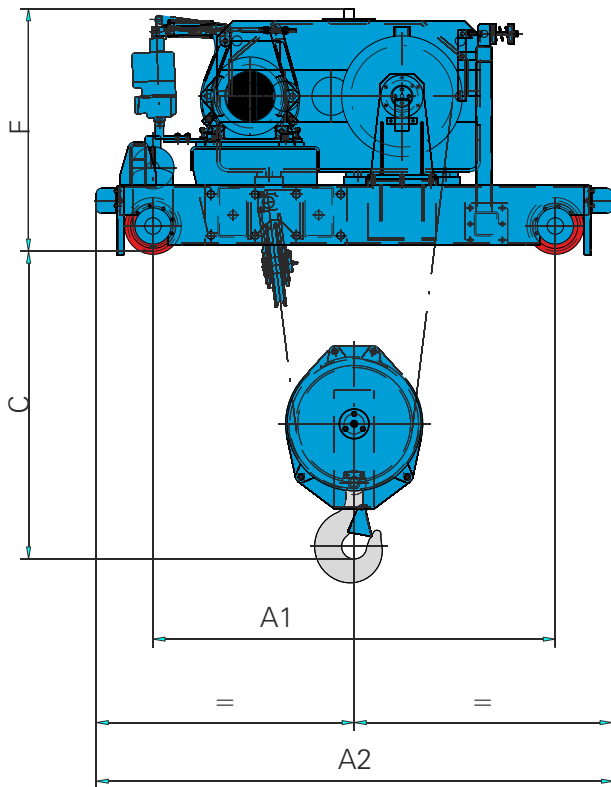

Model	Capacity		Classification		Height			Speed					Dimensions				E/c			Weight		
	Falls	t	FEM	ISO	H1	H2	H3	V1	V2	V3	V4	V5	F	C	A1	A2	H1	H2	H3	H1	H2	H3
GHF	4/2	6,3	5 m	M8	10	15	20	6	8	12	16	20	1075	1005	1900	2465	1500	1800	2000	2600	2700	3000
		8	5 m	M8																		
		10	5 m	M8																		
		12,5	4 m	M7																		
		16	3 m	M6																		
20	2 m	M5																				
GHG	4/2	12,5	5 m	M8	10	15	20	6	8	12	16	20	1220	1270	1900	2465	1800	2000	2240	4700	4800	5100
		16	5 m	M8																		
		20	4 m	M7																		
		25	3 m	M6																		
		32	2 m	M5																		
40	1 Am	M4	1355	1085	2525																	
GHI	4/2	20	5 m	M8	10	15	20	6	8	12	16	20	1450	1630	2200	2825	2000	2240	2600	11200	11600	12500
		25	5 m	M8																		
		32	4 m	M7																		
		40	3 m	M6																		
		50	2 m	M5																		
GHJ	4/2	32	5 m	M8	10	15	20	6	8	12	16	20	1625	1745	2400	3205	2000	2240	2500	15900	16100	17200
		40	5 m	M8																		
		50	4 m	M7																		
		63	3 m	M6																		
		80	2 m	M5																		
GHK	4/2	50	5m	M8	10	15	20	6	8	12	16	20	2150	2055	3500	4532	2550	2800	3050	22000	24000	26000
		63	4m	M7																		
		80	3m	M6																		
		100	2m	M5																		
		125	1Am	M4																		

SELECTION TIME

■ Selection board for open winch selection with 8/2 falls

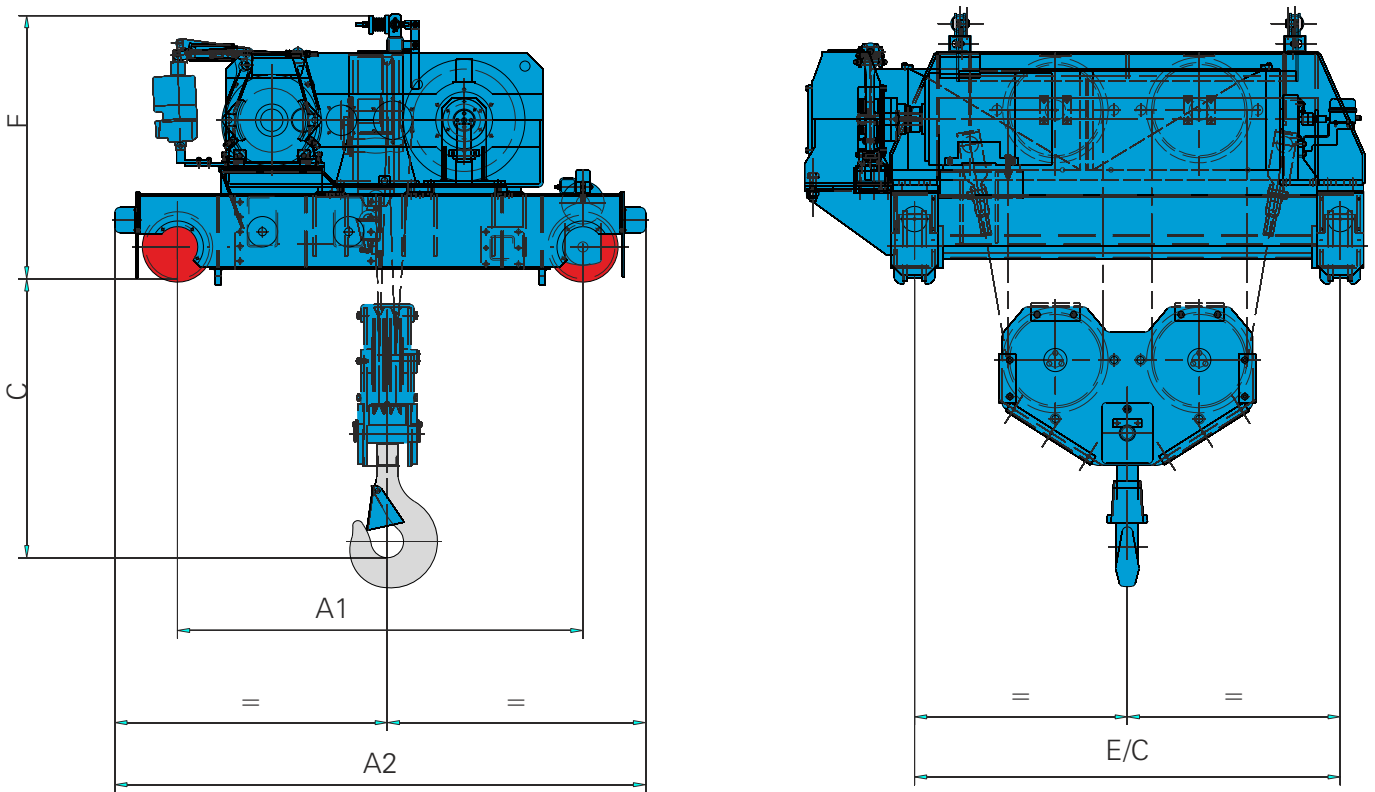

Model	Capacity	Classification		Height			Speed					Dimensions				E/c			Weight		
		Falls	t	FEM	ISO	H1	H2	H3	V1	V2	V3	V4	V5	F	C	A1	A2	H1	H2	H3	H1
GHF	12,5	5 m	M8	10	15	20	3	4	6	8	10	1165	1065	2000	2565	1800	2400	3000	3400	3700	4300
	16	5 m	M8																		
	20	5 m	M8																		
	25	4 m	M7																		
	32	3 m	M6																		
40	2 m	M5	1020																		
GHG	25	5 m	M8	10	15	20	3	4	6	8	1355	1255	2000	2625	2000	2500	3000	5900	6200	6500	
	32	5 m	M8																		
	40	4 m	M7																		
	50	3 m	M6																		
	63	2 m	M5									1210									
80	1 Am	M4	1450	1115	2805																
GHI	40	5 m	M8	10	15	20	3	4	6	8	1545	1555	2400	3205	2240	2500	3150	13400	14000	14600	
	50	5 m	M8																		
	63	4 m	M7																		
	80	3 m	M6																		
100	2 m	M5	1455	1415																	
GHJ	63	5 m	M8	10	15	20	3	4	6	1680	2150	2600	3600	2240	2800	3500	18700	19800	20800		
	80	5 m	M8																		
	100	4 m	M7																		
	125	3 m	M6																		
	160	2 m	M5								2080									2040	1960
GHK	100	5m	M8	10	15	20	3	4	6	2250	1860	3500	4532	2800	3300	3800	24000	26000	28000		
	125	4m	M7																		
	160	3m	M6																		
	200	2m	M5																		
	250	1Am	M4								1760									1660	1560

SELECTION TIME

■ Selection board for open winch selection with 12/2 and 16/2 falls

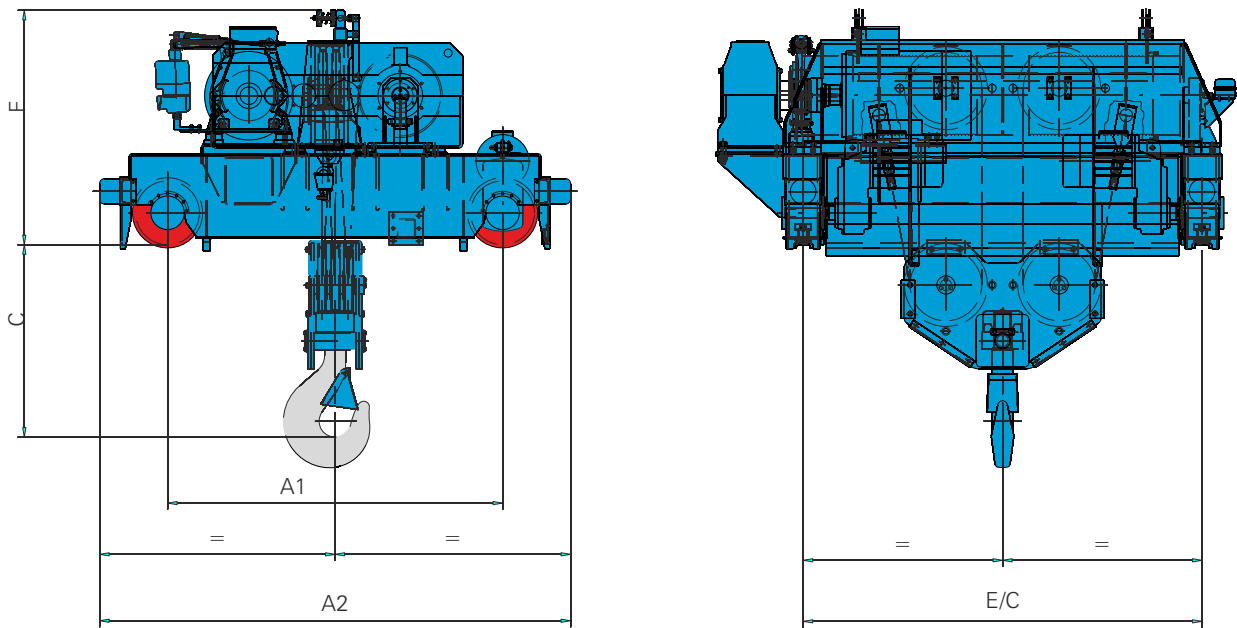

Model	Capacity	Classification		Height			Speed					Dimensions				E/c			Weight		
Falls	t	FEM	ISO	H1	H2	H3	V1	V2	V3	V4	V5	F	C	A1	A2	H1	H2	H3	H1	H2	H3
GHF	25	5 m	M8	10	15	20	2	2,7	4	5,4	8	1350	1100	2000	2625	2500	3150	4000	4100	5500	5900
	32	5 m	M8																		
12/2	40	4 m	M7																		
	50	3 m	M6																		
	63	2 m	M5																		
GHG	40	5 m	M8	10	15	20	2	2,7	4	5,4		1450	1290	2000	2805	2500	3150	4000	7700	9000	10500
	50	5 m	M8																		
	12/2	63	4 m										M7								
		80	3 m										M6								
		100	2 m										M5								
GHI	63	5 m	M8	10	15	20	2	2,7	4	5,4		1545	1875	2400	3205	2600	3500	4200	14900	16500	17300
	80	5 m	M8																		
	12/2	100	4 m									M7									
		125	3 m									M6									
		160	2 m									M5									
GHJ	100	5 m	M8	10	15	20	1	2	2,5	4		1745	2375	2600	3740	2800	3500	4200	21600	23800	25000
	125	5 m	M8																		
	12/2	160	4 m										M7								
		200	3 m										M6								
		250	2 m										M5								
GHK	160	5m	M8	10	15	20	1	2	2,5	4		2350	1885	3500	4532	3300	4050	4800	26000	29000	31000
	200	4m	M7																		
	12/2	250	3m										M6								
		320	2m										M5								
		400	1Am										M4								

Model	Capacity	Classification		Height			Speed					Dimensions				E/c			Weight		
Falls	t	FEM	ISO	H1	H2	H3	V1	V2	V3	V4	V5	F	C	A1	A2	H1	H2	H3	H1	H2	H3
GHJ	160	5m	M8	10	15	20	1,5	2	2,5	3		2450	2270	3500	4532	3300	4050	4800	26000	29000	31000
	200	4m	M8										2170								
	250	3m	M7										2070								
	320	2m	M6																		
GHK	200	5m	M8	10	15	20	1,5	2	2,5	3		2450	2270	3500	4532	3300	4050	4800	26000	29000	31000
	250	4m	M8										2170								
	320	3m	M7										2070								
	400	2m	M6																		

ROTATING OPEN WINCH

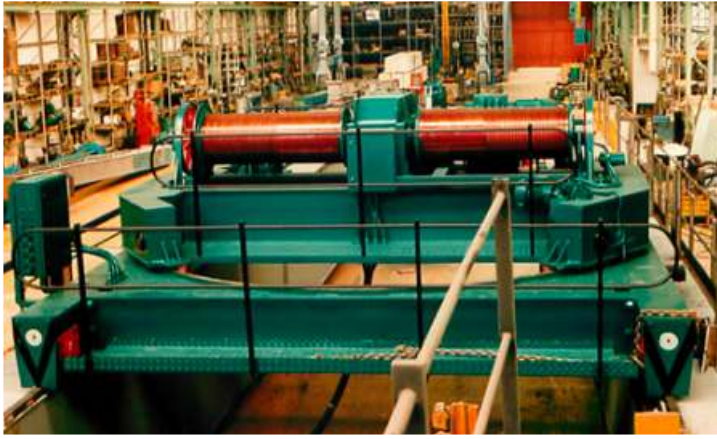

Interesting option to manipulate long products, paper reels, liquid metal or metal scrap crab

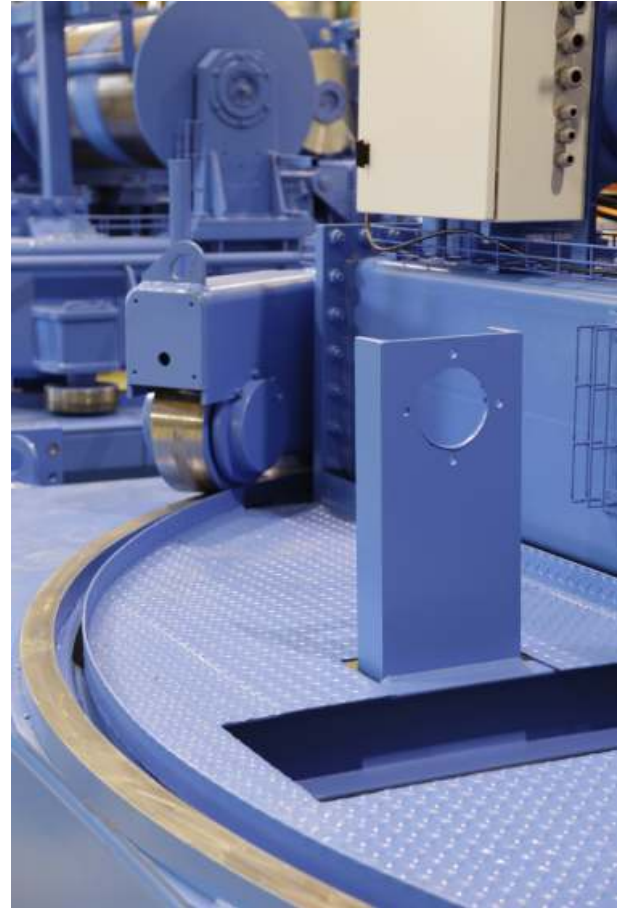

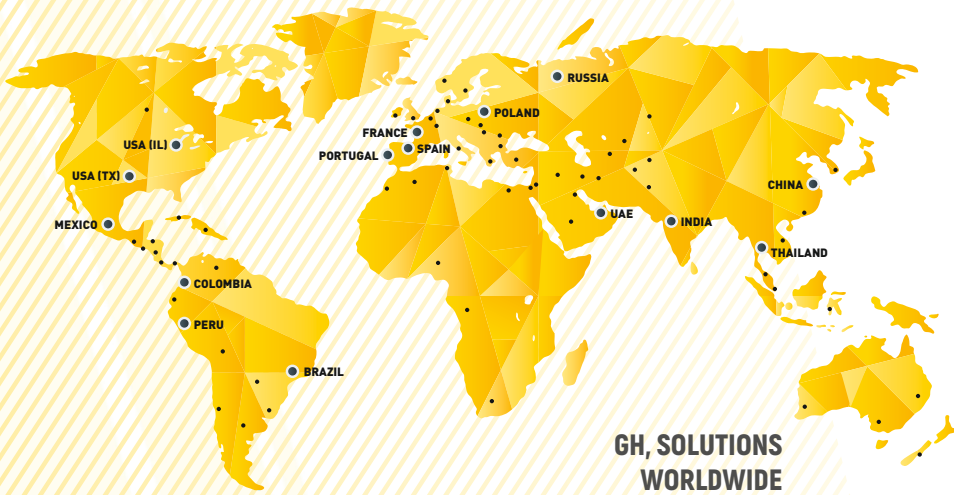

GH, SOLUTIONS
WORLDWIDE

Presence in
+73 COUNTRIES
ON 5 CONTINENTS

+ 112.000
sold cranes

+ 750

IN THE
TOP 5 CRANE
MANUFACTURERS
WORLDWIDE

GH, Spain central offices

-GH-

www.ghcranes.com



Beasain

CENTRAL OFFICES
T: +34 943 805 660
ghcranes@ghcranes.com



Olaberría

T: +34 902 205 100
globalservice@ghcranes.com



Alsasua

T: +34 948 467 625



Bakaiku

T: +34 948 562 611



Jaén

T: +34 902 205 100

GH, subsidiaries in the world



Brazil

Cabreúva

GH DO BRASIL IND. E COM. LTDA.
T: +52 44 22 77 55 03
ghdobrasil@ghdobrasil.com.br



China

Shanghai

GH (SHANGHAI)
LIFTING EQUIPMENT CO., LTD.
T: +86 21 5988 7676
ghchina@ghsa.com



Colombia

Bogotá

GH COLOMBIA SAS
T: +57 1 750 4427
yezpeleta@ghsa.com



France

Couëron

GH FRANCE SA
T: +33(0) 240 861 212
ghfrance@ghsa.com



India

Pune

GH CRANES INDIA PVT. LTD.
T: +91 89561 35444
ghindia@ghsa.com



Mexico

Queretaro

GRÚAS GH MEXICO SA DE CV
T: +66 (0) 2327 9399
M: +66 (0) 8 4660 1365
ghmexico@ghsa.com.mx



Peru

Lima

GH PERÚ S.A.C.
T: +51 987816231
gferradas@ghsa.com



Poland

Kłobuck

GH CRANES SP. Z O.O.
T: +48 34 359 73 17
intertech@ghsa.pl

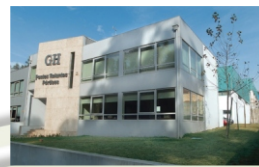

Portugal

Mamede do Coronado

GH PORTUGAL
T: +351 229 821 688
geral@ghsa.com



Russia

Moscow

GH RUSSIA
T: +7 (495) 745 69 26
ghrussia@ghsa.com



Thailand

Chonburi

LGH Cranes
T: +66 (0) 2327 9399
M: +66 (0) 8 4660 1365
ghthailand@ghsa.com



UAE

Dubai

GH Cranes Arabia FZCO
Office no. 517, 5th Floor, Jafza
Building 16, Jebel Ali Free Zone.
P.O Box Number - 263594
T: +971 4 8810773
gharabia@ghcranes.com



USA

Illinois

GH CRANES USA
T: (815) 277 5328
ghcranesusa@ghsa.com



USA

Texas

F&G CRANES
T: (972) 563 8333
info@fg-ind.com

**Lifting
your
world.**